

HRUシリーズ仕様表 [超精密減速機 NDS (Nemoto Drive System)]

形式		減速比	割り出し精度	繰り返し精度	等価出力トルク	瞬時最大許容出力トルク	モータ軸換算イナーシャ I_U	入力軸摩擦トルク T_U	効率係数 F	出力軸イナーシャ I_B	ユニット係数 K	許容スラスト荷重	許容ラジアル荷重	製品重量
枠番	形番	[-]	[弧秒]	[弧秒]	[kgf·m]	[kgf·m]	[kgf·cm·S ²]	[kgf·m]	[-]	[kg·m·S ²]	[m]	[kgf]	[kgf]	[kg]
HRU-75	24	1/24	±60	±10	2.60	7.77	0.00148	0.09	0.60	0.000595	0.0011	100	100	12
	36	1/36	±60	±10	2.64	7.92	0.00143	0.07	0.50					
HRU-100	24	1/24	±30	±5	6.86	20.55	0.00960	0.15	0.60	0.00268	0.0015	200	200	50
	36	1/36	±30	±5	7.01	21.02	0.00935	0.13	0.55					
HRU-135	20	1/20	±30	±5	11.43	34.31	0.0144	0.17	0.60	0.01064	0.0021	300	300	75
	40	1/40	±30	±5	12.27	36.80	0.0124	0.15	0.50					
HRU-195	20	1/20	±30	±5	27.7	83.12	0.066	0.45	0.65	0.0596	0.0027	500	500	200
	40	1/40	±30	±5	29.4	88.13	0.055	0.40	0.55					
	60	1/60	±30	±5	29.75	89.22	0.053	0.35	0.50					
HRU-260	30	1/30	±30	±5	44.70	134.09	0.170	0.60	0.65	0.1883	0.0033	800	800	400
	60	1/60	±30	±5	47.04	141.12	0.154	0.50	0.55					

2012/09/07

HRUシリーズ寸法図

HRU-75

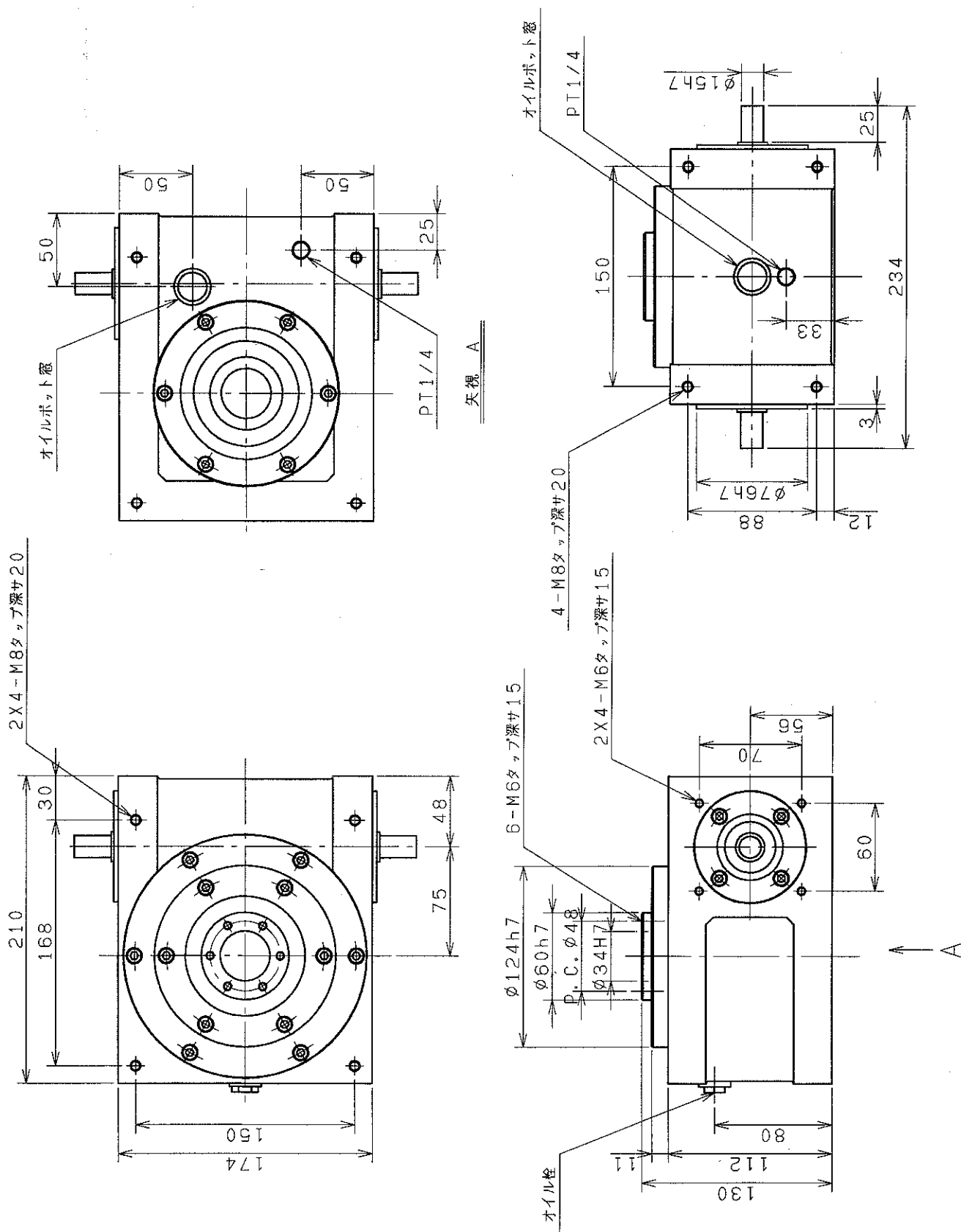

HRU-100

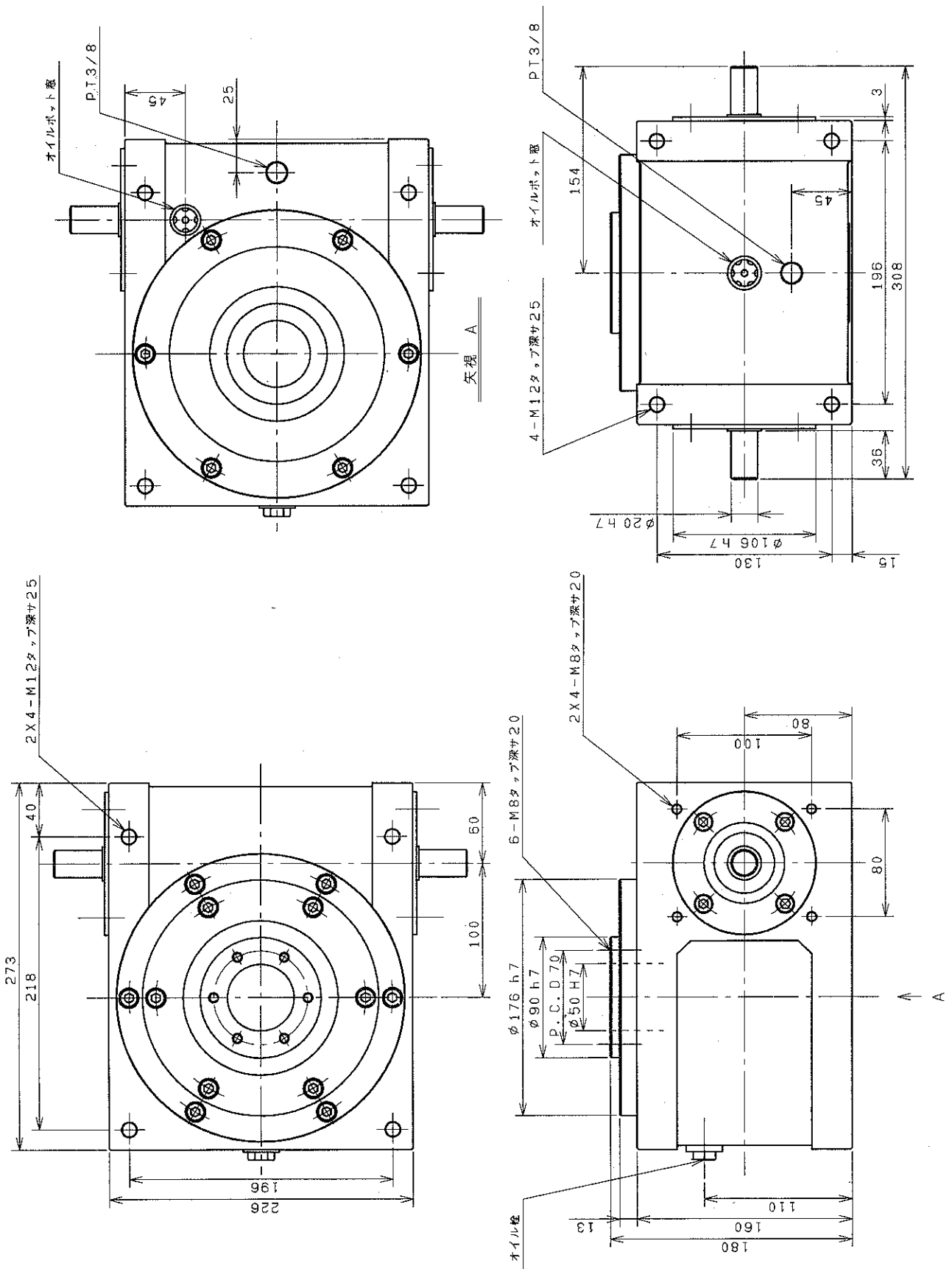

HRU-135

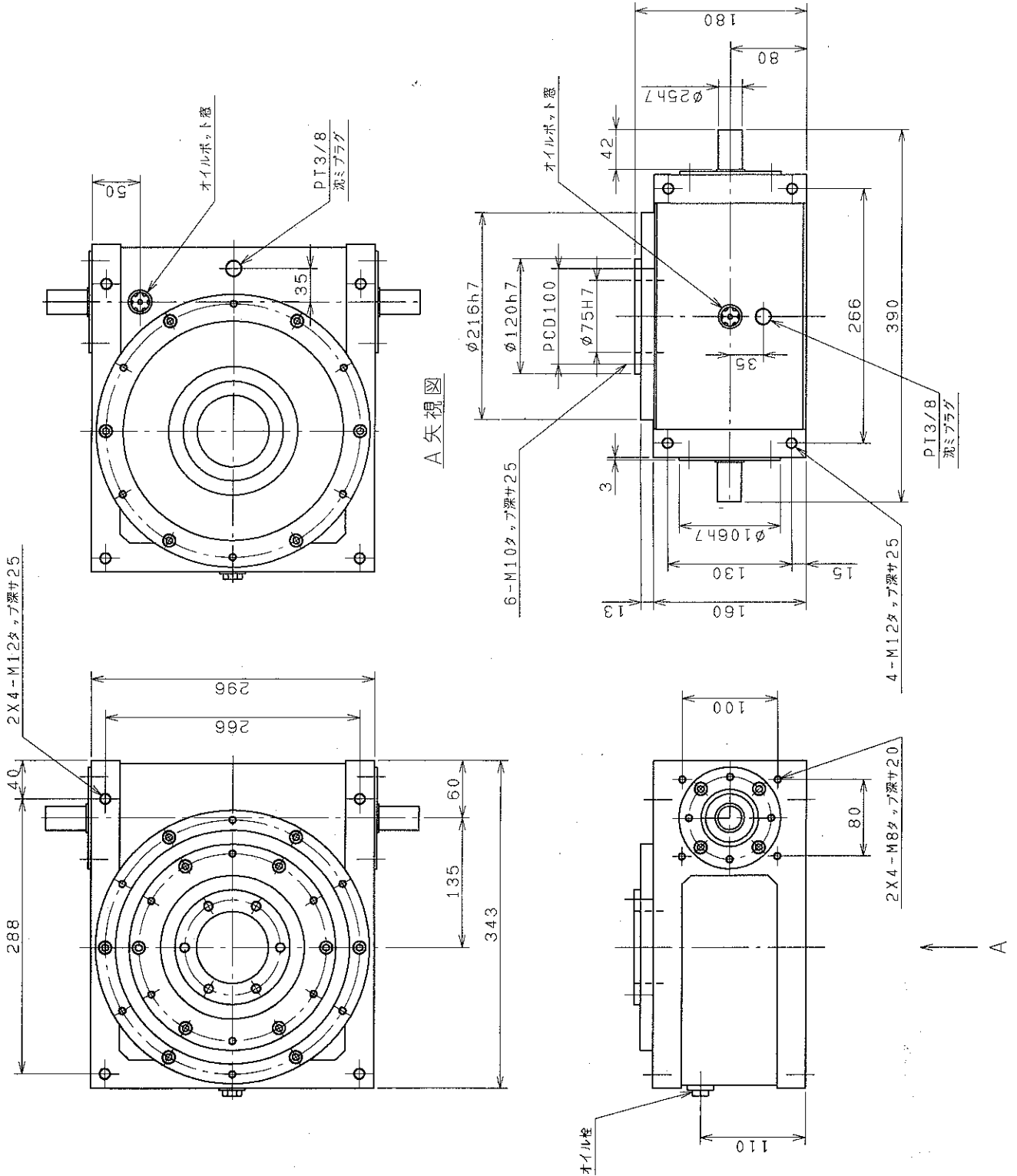

HRU-195

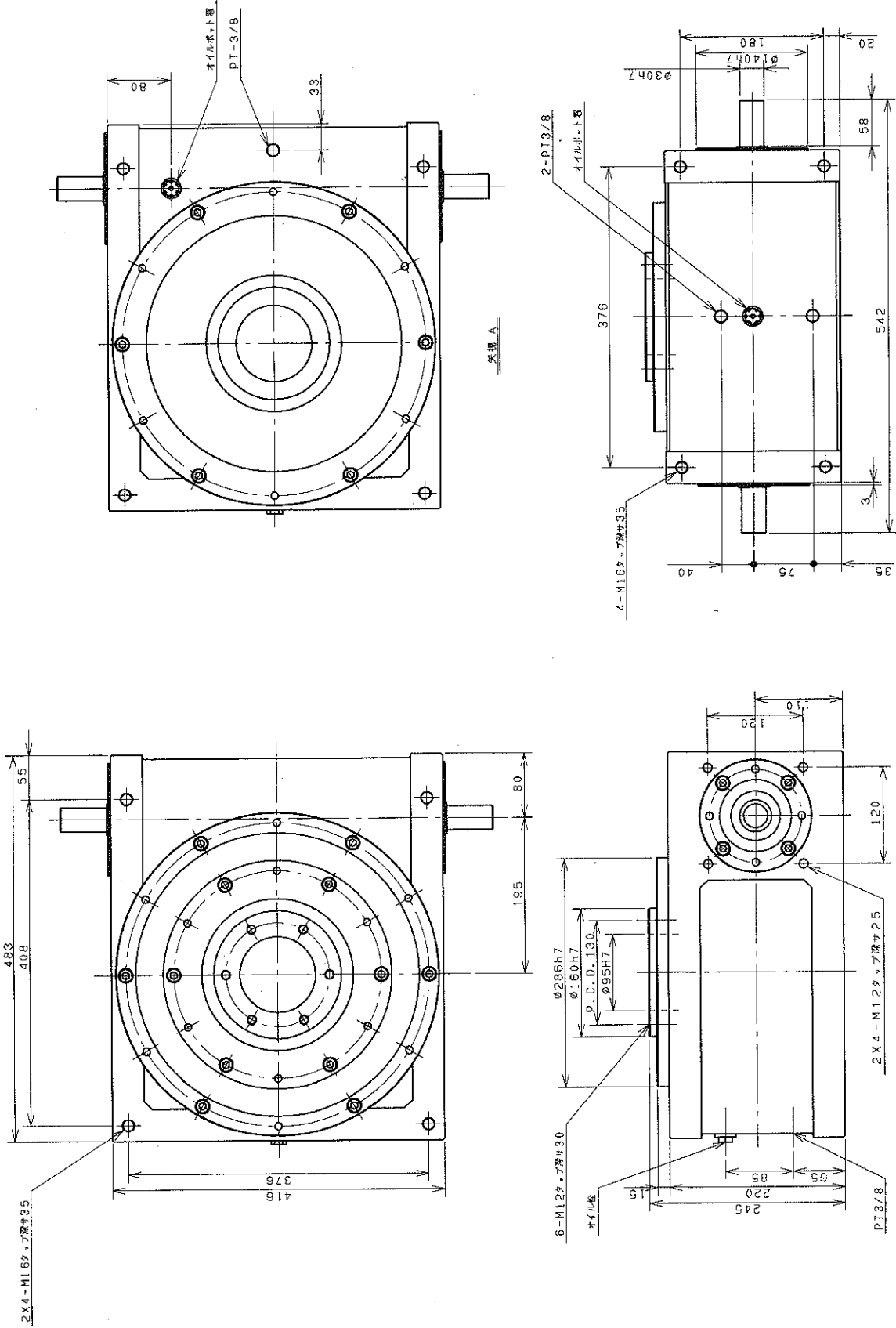

HRU-260

